



ISO 9001:2008 CERTIFIED

**Magnetic Liquid-Level Gauges
For Industrial Service**

Application

M6200 Series gauges are widely used to measure liquid levels of fuels, hydraulic fluids, refrigerants, lube oils and cryogenic products in pressurized tanks, columns or vessels up to 300 PSIG [20,7 Bar]. Stainless steel mounting bolts are optional.

General Information & Features

Direct-reading fractional dials, gear actions and aluminum floats are standard models. Remote-reading TwinSite™ senders are available for some models. Lever actions are available for centerline mounted models. Nitrile rubber floats are optional. Please refer to instructions on “How to Order” on reverse side of this technical data sheet.



Model #	Type	Mounting	Standard Direct Reading Dial	Remote-Reading Sender
M6281	Jr.	Top	5323S01793	N/A
M6240	Sr.	C/L or Angle	N/A	Specify 0-90 or 240-30 Ohm Twinsite™ Sender
M6243		Top	5025S00570 (Side Reading)	N/A
M6260		C/L or Angle	5002S00062	
M6280		Top	5013S00456 (4")	
M6283		C/L or Angle		
M6290		Top		
M6293		C/L or Angle		
M6250		Sr. Switchgauge	Top	Standard Switch #5023S00778, S.P.S.T., 150 VDC, 1/2 Amp. Please furnish tank drawings and switch points so proper gauge and calibration can be supplied. Other switches available, see DS-364.
M6253	C/L or Angle			

Extra Cost Options:

1. For a nitrile rubber float, suitable for pressures up to 50 PSIG maximum or 250 PSIG maximum (specify if over 50 PSIG) in place of standard aluminum float, change prefix “M” to “N”.
2. For lever action on C/L mounted gauges only, instead of gear action, add prefix “L” to the model number.
3. Neoprene Sr. gasket, part number 15-836.
4. Viton Sr. gasket, part number 15-415.
5. Teflon Sr. Gasket, part number 15-401.

M6200

Magnetic Liquid-Level Gauges For Industrial Service

Gear Action, available on all models (Sr. Head shown)

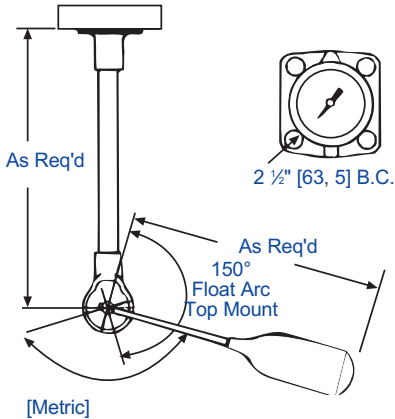

Senior, Twinsite Sender

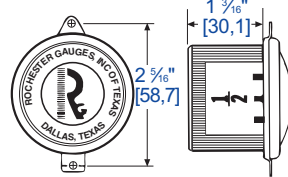
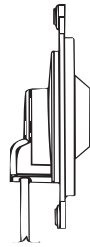
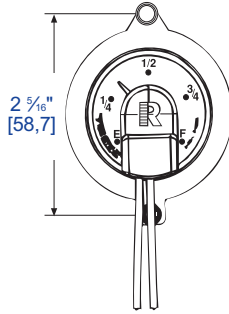

Senior, Side-View Dial

Senior Dial

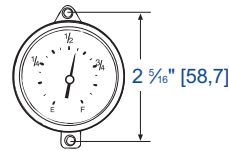

Junior Dial

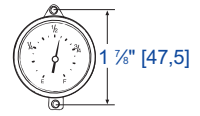

Lever Action, available on all centerline models (Jr. Head shown)

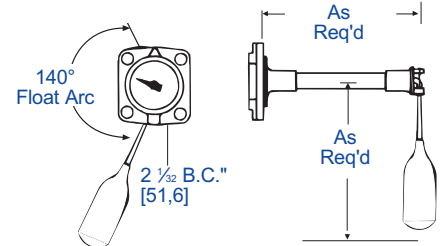

General Specifications *

Mounting

Gear-action gauges are suitable for top, side, end or angle mounting. Lever-action gauges are suitable for centerline mounting on flat end of tank only.

Accuracy

Depends on proper sizing of gauge and tank configuration. Normally, Junior direct-reading dials are a $\pm 5\%$; Senior dials are $\pm 3\%$; side-reading dials are $\pm 4\%$; TwinSite™ senders are $\pm 7\%$; and 4" dials are $\pm 3\%$.

Temperature

Standard operating temperature range -40°F to 158°F , -40 to 70C .

Humidity

For high humidity and marine applications, painting of exposed portion of gauge, less dial, is recommended.

Shock

Passes MIL-S-901 B Naval Standard Shock test.

Vibration

Passes MIL-STD-167 Naval Standard Vibration test.

Power

0.5 watts maximum for TwinSite™ versions.

Tank Pressure

Up to 300 PSIG [20,7 Bar] with standard aluminum float and steel mounting screws; up to 450 PSIG [31 Bar] with standard aluminum float and stainless steel mounting screws.

Approvals

Model M6200 direct indicating gauges are available with UL listing for flammable liquids. Models M6253 and M6283 are UL recognized refrigeration components.

Note: For installation instructions see MS-501/502 (mounting standard).

Materials of Construction *

Head

Die-cast aluminum.

Gear Housing

Die-cast aluminum or acetal

Centershaft, Support Tube & Float Rod

Tempered aluminum.

Gears, Cross Stud & Bearings

Stainless steel.

Drive Magnet

Alnico.

Float

One-piece aluminum is standard. Nitrile rubber available.

Gasket

UL recognized Buna-N (#15-7 Jr. gasket and #15-4 Sr. gasket).

Standard Direct-Reading Dial

Jr. dial is hermetically sealed polycarbonate.

Sr. dial is aluminum with acrylic crystal, hermetically sealed.

Side-Reading Dial

Aluminum with polycarbonate crystal, hermetically sealed.

TwinSite™ Dial

Polyamide.

4" Dial

Aluminum housing, dial and bezel with glass crystal, hermetically sealed.

Screws

Zinc-plated steel.

(Jr. are $\frac{1}{4}$ " -28 x $\frac{7}{8}$ " long; Sr. are $\frac{5}{16}$ " -24 x $\frac{7}{8}$ " long).

* Materials and specifications are subject to change without notice. Ratings are subject to change due to temperature and other environmental considerations.

When Ordering, Specify:

1. Gauge Model Number
2. Tank diameter and riser height
3. Mounting location
4. Ohm range on TwinSite™ versions
5. Preferred switch on switchgauges, if other than standard
6. Any listed options, or unlisted preferences.